



BRITISH WATER
expertise worldwide



Code of Practice

Guide to the Desludging of Sewage Treatment Systems

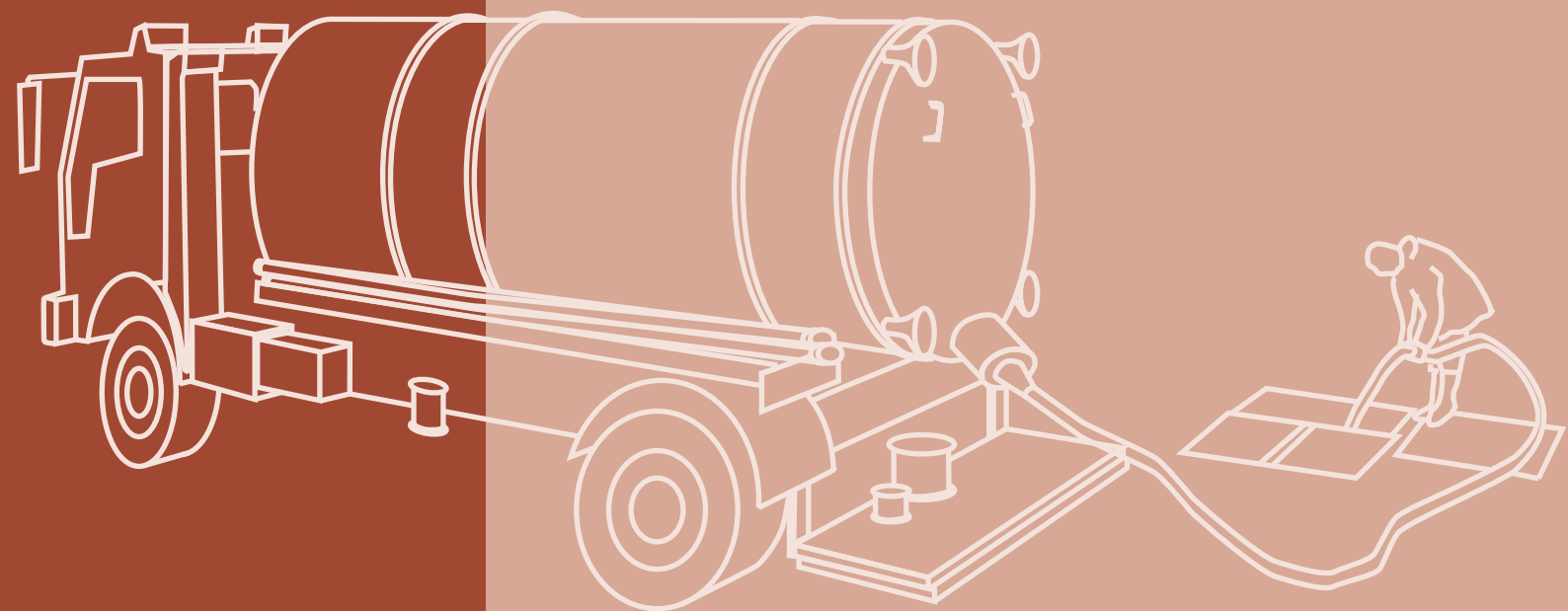



Guide to the Desludging of Sewage Treatment Systems

Contents

- 1. Scope
- 2. Introduction
- 3. What is sludge and where does it come from
- 4. Why does it need removing
- 5. How do I know the plant needs de-sludging
- 6. Duty of Care on disposal - giving waste to other people
- 7. De-sludging frequency
- 8. Actual Vacuum/Suction tanker visits
- 9. Check on qualifications of contractor

Please note: The environmental regulators the Environment Agency, the Environment and Heritage Service (Northern Ireland) and the Scottish Environment Protection Agency support the use of this code of practice, but the Agencies do not specifically endorse any particular manufacturer's product.

"Simplified diagram to show where solids collect"

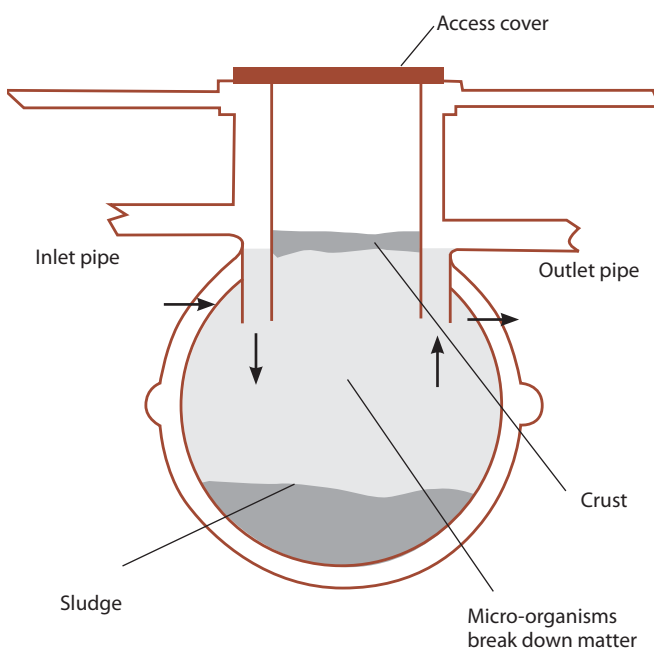

1. Scope

This guide outlines what sludge is, where it comes from and the need for its safe removal and legal disposal.

2 Introduction

Sludge production is a natural process which happens in all correctly operating sewage treatment systems and de-sludging is crucial to the continued correct and satisfactory performance of sewage treatment plants.

This guide has been created to enable owners and users to understand the operation of sewage treatment systems, especially how and why they produce solids (called sludge) and why it is important to remove it periodically. It should be read in conjunction with the manufacturers' literature and other supporting guidance documentation.

It is not a definitive document but it does provide an outline of sludge development and its removal, correct and safe disposal that all reputable disposal contractors should provide as part of the de-sludging service.

Non-mains sewage treatment system owners should enter into a maintenance contract with a competent operator which uses suitably qualified personnel who have passed the British Water Maintenance and Servicing Training Scheme. A list of certified maintenance engineers is available on the British Water website.

3 What is sludge and where does it come from?

Sludge is the solid matter produced in and by all sewage treatment systems. It consists of inert solids and biological matter.

The inert solids come from the solid matter flushed into the sewage system from the toilet, the kitchen, laundry and washing in the household.

Some of the biological matter is in the wastewater but most is produced as a consequence of the natural processes (growth of micro-organisms) which are an essential part of the operation and actions of the treatment plant as it purifies the wastewater (sewage).

Most sewage treatment systems involve a number of stages.

- The plant first removes solids that will settle (sink to the bottom of the tank) easily, this is a simple settlement process and it also reduces the number of subsequent stages.
- The remaining pollution that does not settle is broken down by natural biological processes and in doing so produces more solids which settle out.
- A correctly operating sewage treatment plant produces
 - i. a clear water effluent that can safely be discharged locally into the environment, and
 - ii. sludge containing inert solids and solids produced by the operation of the plant itself and which needs to be removed regularly and disposed of safely and correctly.



Jet-washing the system should only be carried out as recommended by the manufacturer



4 Why does it need removing?

Sewage treatment plants only have a finite volume in which the sludge accumulates as the sewage is treated and which when it is full will require de-sludging. If the sludge is not removed the treatment plant will not work efficiently and the quality of the treated effluent will gradually worsen. The effluent will not comply with the regulatory requirements and so will contaminate the environment and/or damage any soak away, drainage field, ditch or stream that the unit discharges into.

It is important to note that if the discharged effluent does not comply with the “Permit or Consent to Discharge or the Authorisation” issued by the regulator that this is a civil offence and so may have legal consequences – court appearances and potentially fines, especially for commercial organisations.

5 How do I know the plant needs de-sludging?

The plant should be desludged in accordance with the manufacturer’s recommendations, but the following are signs that a treatment plant requires desludging:

- A thick crust on the surface
- A poor quality liquid effluent discharge usually containing solids
- Persistent foul odour which is significantly worse than the normal smell
- A core/dip sample which indicates that the treatment plant is more than two-thirds full of heavy sludge.

6 Duty of Care on Disposal - giving waste to other people

When you arrange disposal of your sewage sludge you have a legal and social obligation for its disposal, called the ‘Duty of Care’. The duty of care requires you to take all reasonable steps to ensure that the waste is safely disposed of by an authorised person. It applies to everyone involved in handling wastes including sewage sludge, from the person who ‘produces’ it to the person who finally disposes of it or uses the material.

If you allow someone else to deal with the waste on your behalf (like the vacuum tanker operator) it is your duty to make sure that:

- The person is authorised to take the material away – ask them to produce evidence and check that they are registered with the Environment Agency as a waste carrier. If they cannot do this don’t allow them to take the sludge away and contact the Environment Agency.
- The waste sludge is properly disposed of. Most sludge is either taken to a licensed waste reception facility or sewage treatment works or legitimately disposed of to land.
- You should receive a Transfer Note - this should describe the quantity and type of waste that has been taken away, and ensures that the operator is handling and disposing of the sludge correctly. You must keep copies of transfer notes for a minimum of 2 years.

The Government has produced statutory guidance for the Duty of Care “Waste Management – The duty of care – A Code of Practice” March 1996. (ISBN 0-11-753210-X)

7 De-sludging frequency

Normally manufacturers make recommendations and the desludging intervals, as defined in the Operation and Maintenance manual, should be followed. In the absence of a manual or any recommendations the following intervals are suggested:

- Domestic Sewage/Wastewater Treatment Plants – half-yearly
- Commercial Sewage/Wastewater Treatment Plants – quarterly

It should be recognised that there are occasions when these guidelines can be varied. In the case of a lightly loaded treatment plant the time between desludging operations may be longer than would normally be recommended. You should be guided by your supplier/service provider or the company with which you have a maintenance contract.

8 Vacuum/Suction Tanker visits

It is good practice that the sequence of operations should be as follows:

- The tanker driver reports to the house-holder or site contact
- The driver should take care with vehicular access – width/height/ground stability in and out; paying careful attention to avoid property damage including spillages & oil leaks at all times
- Responsible Waste Contractors (desludging companies) will audit their services and assure a competent and reliable standard. They should provide feedback on the state of the sewage treatment plant if the visit is not supervised by a suitably qualified Sewage Treatment Plant Engineer
- The responsibility for organising a de-sludging contract should be agreed between the client (owner) and the



supplier/contractor when the sewage treatment plant is installed or ownership transferred, it can be included within the service contract

- The de-sludging process, irrespective of plant type or manufacturers' instructions, should move logically through the system generally from the Primary Zone to the Humus/Final Settlement zone and include both primary and/or final effluent pumping stations if they are part of the system. It should follow the sequence:
 - first should be the removal of the crust
 - then the settled sludge
 - followed by clearing any deleterious material throughout the system including all other accumulated sludges
- Jet-washing throughout the sewage/wastewater treatment plant to be carried out if and as required in accordance with the manufacturers' instructions
- All tanker service technicians should be aware of correct and

proper methods of desludging and have a general idea of the governing legislation

- Tanks in the system should be re-primed/filled as soon as possible after emptying, especially in wet conditions where a local water table is close to tank installation depth or the biozone is left exposed
- Tanker drivers and operating companies should advise on access requirements; the optimum distance for de-sludging is generally 30 metres linear distance from closest hard standing for the tanker

9 Check the qualification/references of the desludging contractor

It is wise to check that the contractor has suitable regard for regulatory compliance, Health and Safety, correct disposal of sludge and good working practices. The provision of references who have agreed that they can be contacted will be helpful.

Please note:

1. The sewage treatment system should be sized in accordance with the British Water design Code of Practice Flows and Loads 3 which can be downloaded from http://www.britishwater.co.uk/publications/publications_and_technical_guides.aspx
2. It is advisable that a service agreement is entered into with a company with suitably qualified staff, preferably staff who are listed on the British Water list of Accredited Service Engineers which can be viewed at http://www.britishwater.co.uk/ptp_engineers/Accredited_Service_Engineers.aspx
3. Use of the design Code of Practice and accredited service engineers is recommended in the UK Environment Agencies Pollution Prevention Guidelines Number 4 (PPG4) which can be accessed at <http://publications.environment-agency.gov.uk/pdf/PMHO0706BJGL-E-E.pdf>
4. A summary of Duty of Care requirements and responsibilities is available at <http://www.defra.gov.uk/environment/waste/legislation/pdf/dutyofcare-summary.pdf>

Other British Water publications available at www.britishwater.co.uk are:

- A. Code of Practice: Guide to the Installation of Sewage Treatment Systems
- B. Code of Practice: A Guide for Users of Sewage Treatment Systems

Please note the following statement by British Water

Subject as stated below, no responsibility, duty of care or liability whatsoever (whether in contract or tort or otherwise including, but not limited to, negligence) is or will be accepted by British Water, its officers, employees, agents or members to any user of this guidance or any other person in connection with or in relation to this guidance.

Subject as stated below, British Water, its officers, employees, agents and members do not accept any responsibility or liability for any loss or damage caused to any person who acts or refrains from acting as a result of anything contained in or omitted from this guidance or in reliance on the provisions of or material in this guidance, whether such loss or damage is caused by negligence or otherwise.

Nothing in this disclaimer shall be construed as excluding or limiting the liability of British Water or any of its officers, employees, agents or members for death or personal injury resulting from the negligence of such persons or for fraud.

This guidance does not constitute legal, technical or other advice and it should not be regarded as such. Anyone requiring advice on any of the matters referred to in this guidance, including on how to ensure compliance with any relevant legal or regulatory requirements, should consult their legal or other appropriate professional advisers.

Nothing in this guidance is intended to be or should be construed as advice on the merits of, or a recommendation in relation to, any particular product or product provider and no representation is made that any member of British Water operates or will operate in accordance with this guidance.

Each part of this disclaimer shall be construed as a separate and severable part, and if one or more parts is held to be invalid, unlawful or otherwise unenforceable, the remaining parts shall remain in full force and effect.

